

NFDI4
MICROBIOTA

de NBI
GERMAN NETWORK FOR BIOINFORMATICS INFRASTRUCTURE

jLAB

JUSTUS-LIEBIG-
UNIVERSITÄT
GIESSEN

Diversity Calculation



	Tuesday, Oct 8th	Wednesday, Oct 9th	Thursday, Oct 10th
10:00-10:30		QIIME2 and Qiita	Buffer for Hands-On, Coffee break in-between
10:30-11:00		Qiita Hands-On	
11:00-11:30	Welcome & Intro		
11:30-12:00	From raw data to feature tables	Coffee Break (~15min)	Coffee Break (~15min)
12:00-12:30		Qiita Hands-On	Buffer for Hands-On
12:30-13:00		Lunch Break	Closing remarks and Farewell
13:00-13:30	Lunch Break		
13:30-14:00		QIIME2 Hands-On	
14:00-14:30	Sequence quality control		
14:30-15:00	Coffee Break	Coffee Break	
15:00-15:30	QC Hands-on	Diversity Calculation	
15:30-16:00		QIIME2 Hands-On (cont'd.)	
16:00-16:30			

Contents

1. Alpha Diversity
2. Beta Diversity
3. Dimensionality Reduction (PCoA)

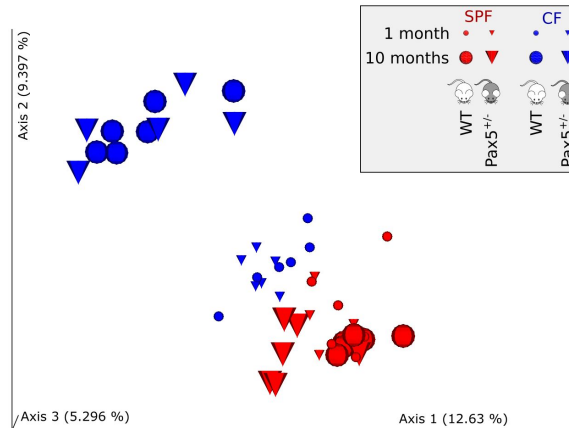
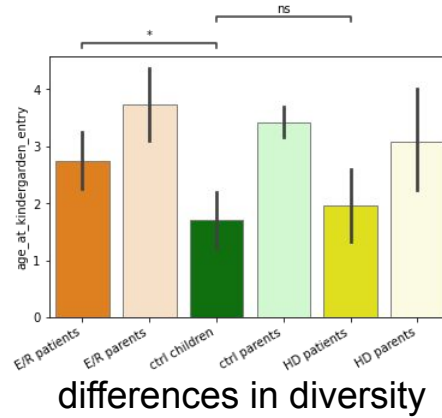

1. Alpha Diversity

- a. observed features
- b. Chao1
- c. Shannon
- d. Faith's PD

2. Alpha Diversity

- one sample at a time
- "how complex is one sample?"
- alternative perspectives
 - a. richness: observed_features
 - b. richness: Chao1
 - c. evenness: Shannon
 - d. phylogenetic diversity: Faith's PD

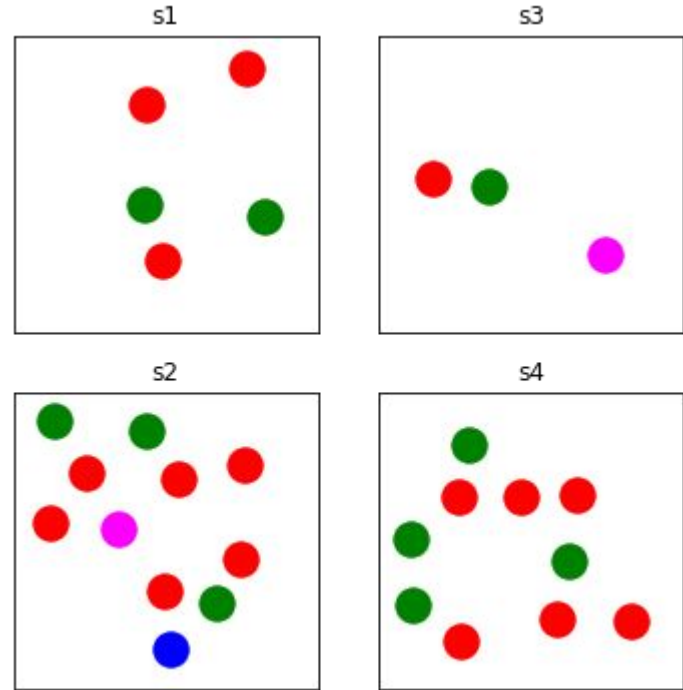

Alpha Diversity: mouse gut microbiome

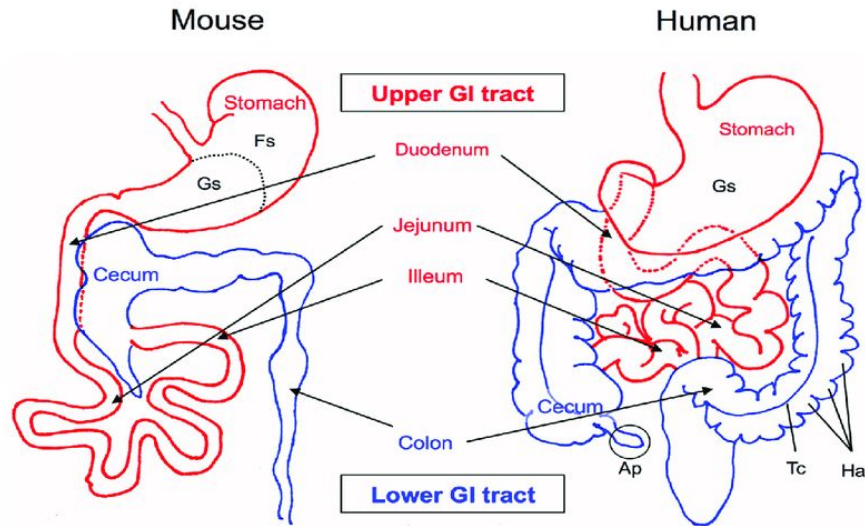

Nishiyama et al. (2016) *microorganisms*

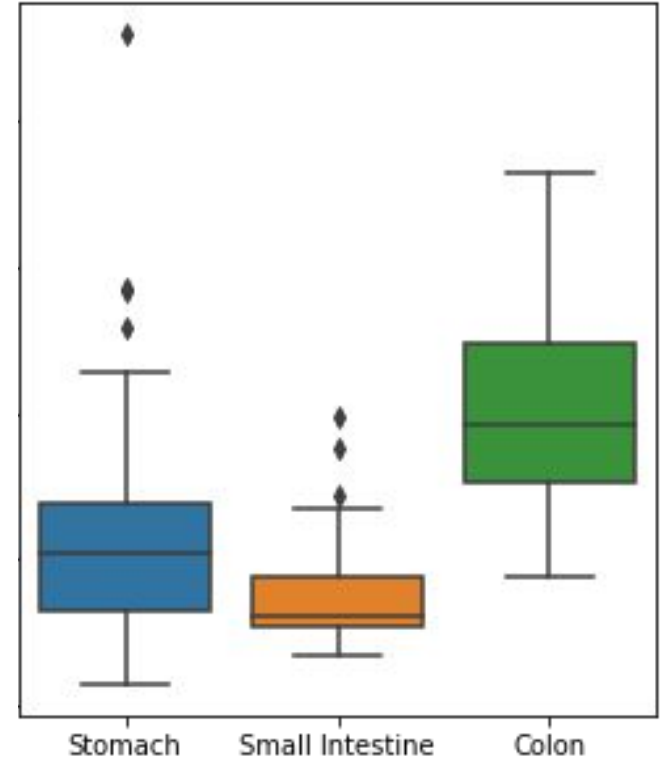

2. Alpha Diversity - a: observed features

- richness
- simple:
count number of features

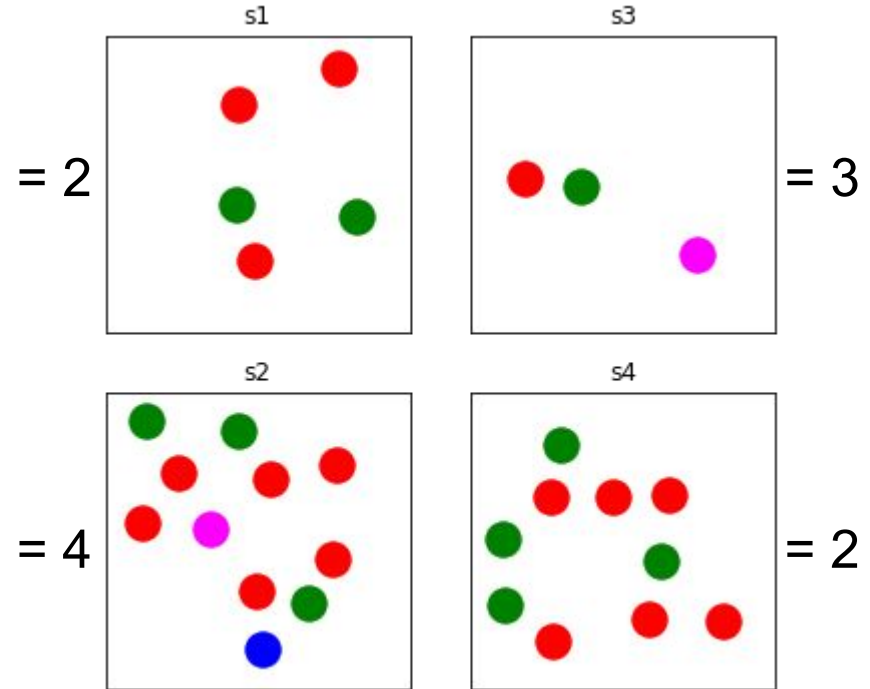

2. Alpha Diversity - b: Chao1

- richness
- simple:
count number of features
- + emphasize singletons

$$chao1 = S_{obs} + \frac{F_1(F_1 - 1)}{2(F_2 + 1)}$$

F_1 = features with count 1
 F_2 = features with count 2
 S_{obs} = observed features

Anne Chao

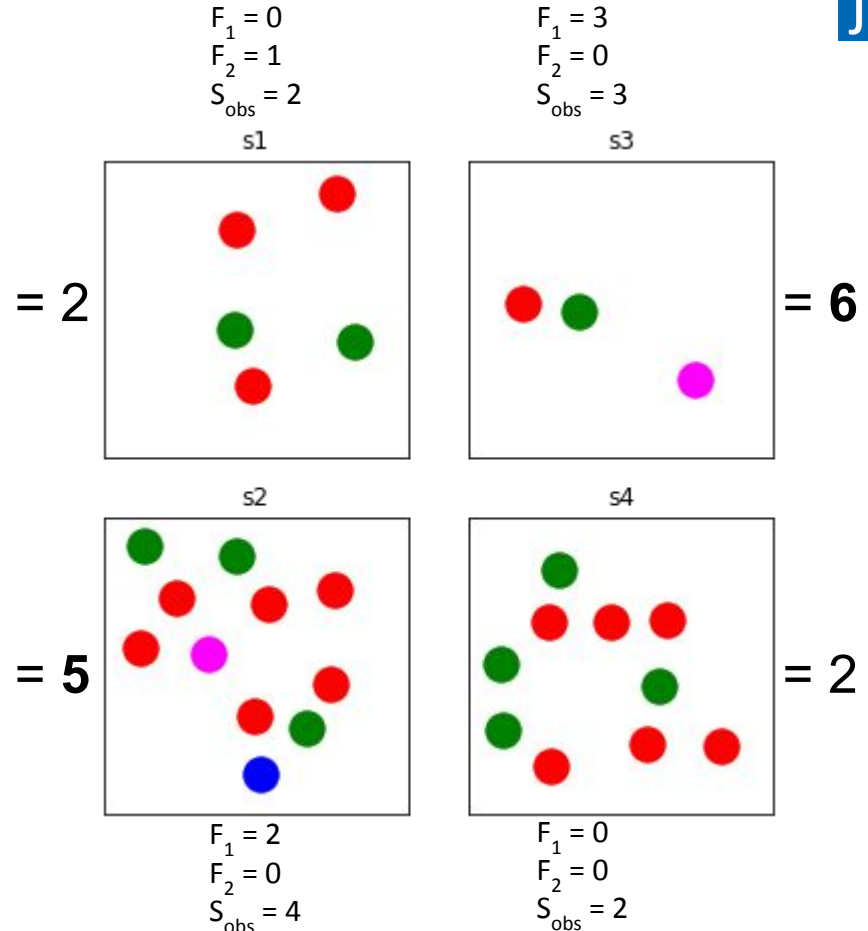

2. Alpha Diversity - b: Chao1

- richness
- simple:
count number of features
- + emphasize singletons

$$chao1 = S_{obs} + \frac{F_1(F_1 - 1)}{2(F_2 + 1)}$$

F_1 = features with count 1

F_2 = features with count 2

S_{obs} = observed features

 Anne Chao (1984) *Scand J Statist* " Nonparametric Estimation of the Number of Classes in a Population"

"when most of the information is concentrated on the low order occupancy numbers"

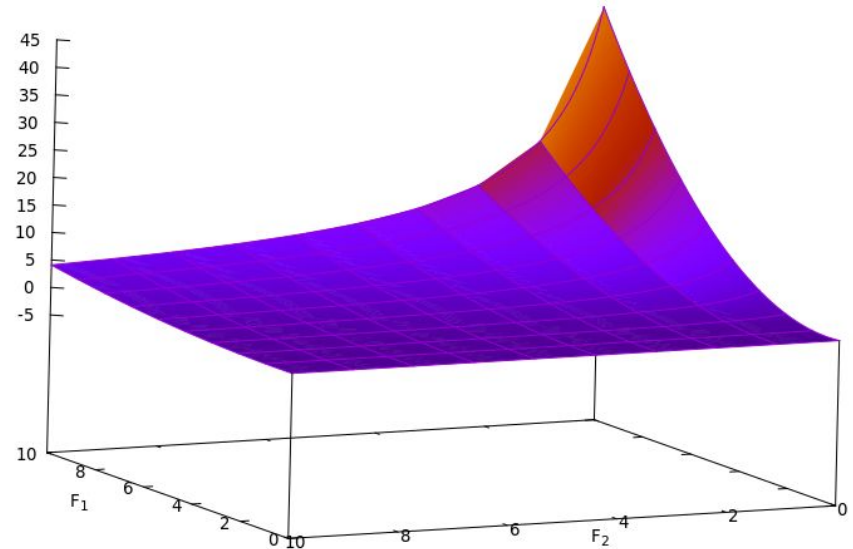

Anne Chao



2. Alpha Diversity - c: Shannon

- evenness

$$H = - \sum_{i=1}^s (p_i \log_2 p_i)$$

$$p_{\text{red}} = 3/5$$

$$p_{\text{green}} = 2/5$$

$$p_{\text{red}} = 1/3 \quad p_{\text{magenta}} = 1/3$$

$$p_{\text{green}} = 1/3$$

= 0.970951

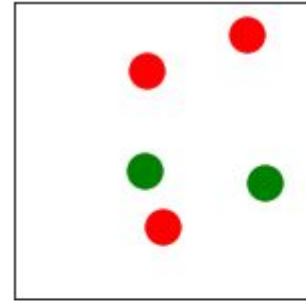

= 1.584963

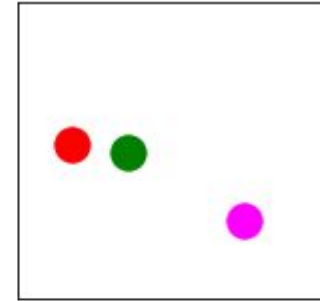

= 1.617190

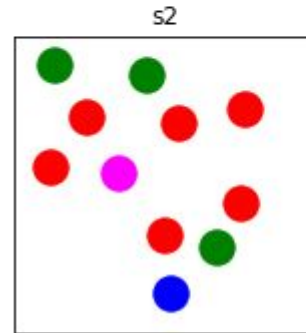

= 0.970951

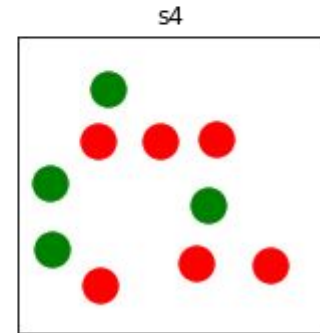

$$p_{\text{red}} = 6/11 \quad p_{\text{magenta}} = 1/11$$

$$p_{\text{green}} = 3/11 \quad p_{\text{blue}} = 1/11$$

$$p_{\text{red}} = 6/10$$

$$p_{\text{green}} = 4/10$$

Claude Shannon

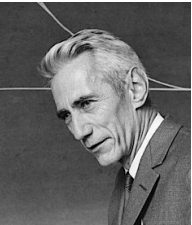

2. Alpha Diversity - c: Shannon

- evenness

$$H = - \sum_{i=1}^s (p_i \log_2 p_i)$$

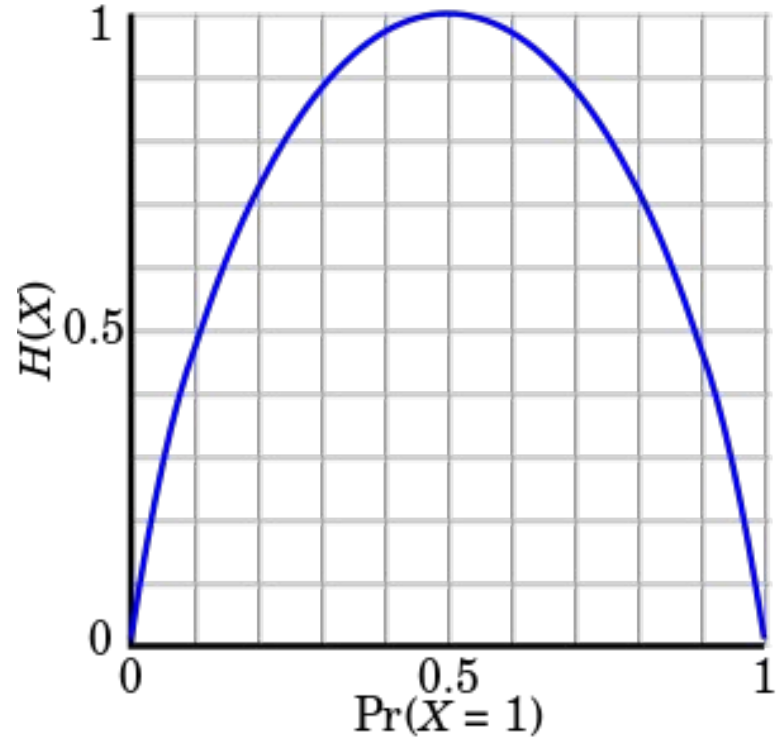

Claude Shannon

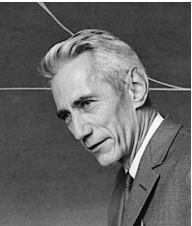

2. Alpha Diversity - d: Faith's PD

- captured evolutionary diversity
- needs a phylogenetic tree!

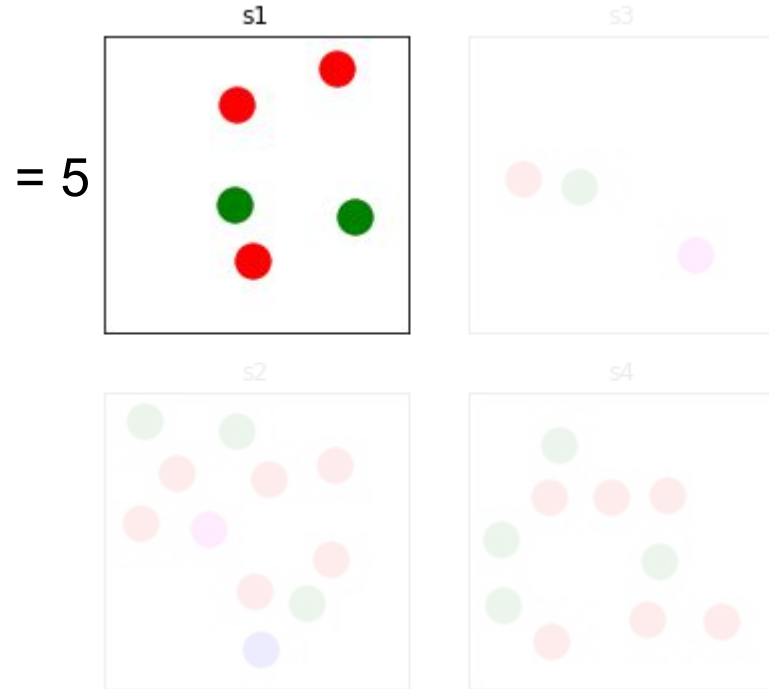
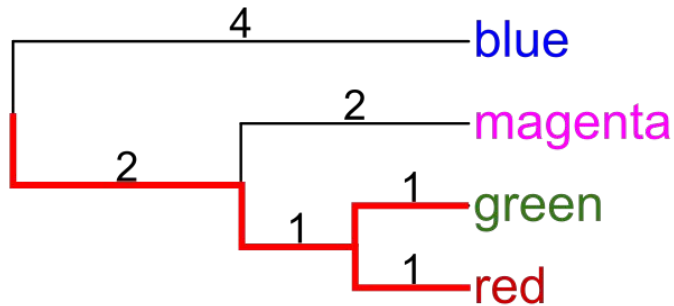

Daniel Faith



2. Alpha Diversity - d: Faith's PD

- captured evolutionary diversity
- needs a phylogenetic tree!

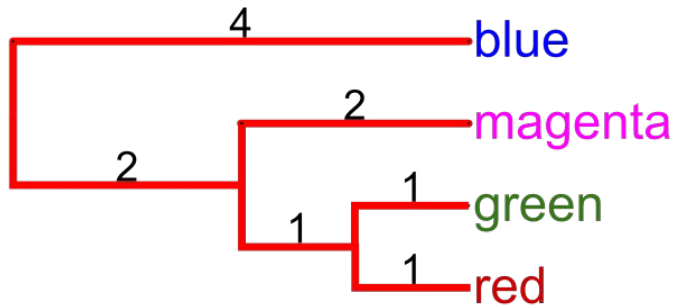

Daniel Faith

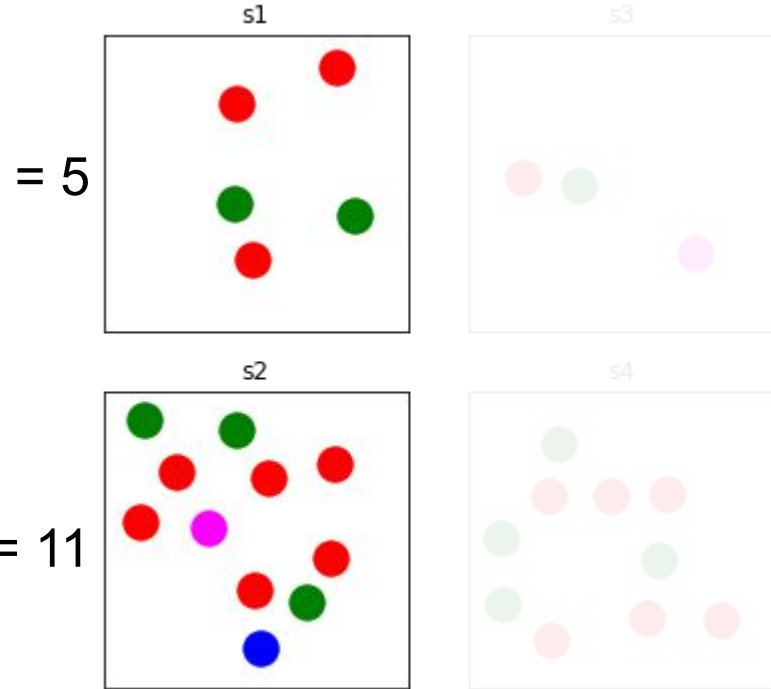

2. Alpha Diversity - d: Faith's PD

- captured evolutionary diversity
- needs a phylogenetic tree!

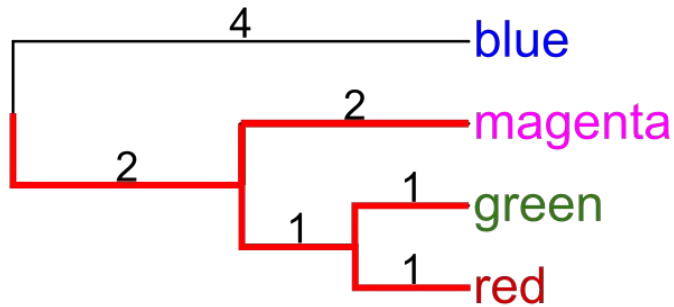

Daniel Faith

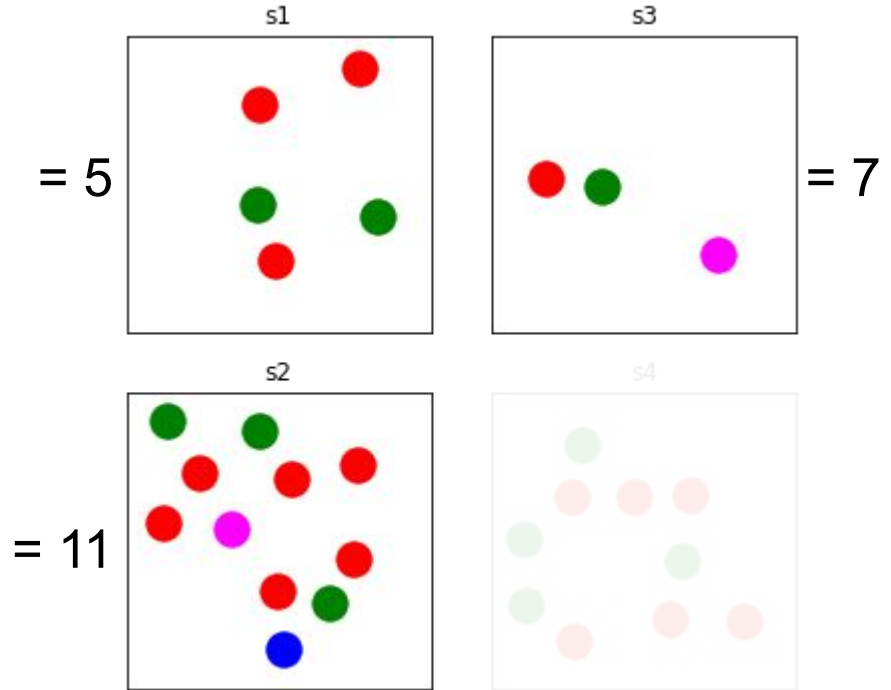

2. Alpha Diversity - d: Faith's PD

- captured evolutionary diversity
- needs a phylogenetic tree!

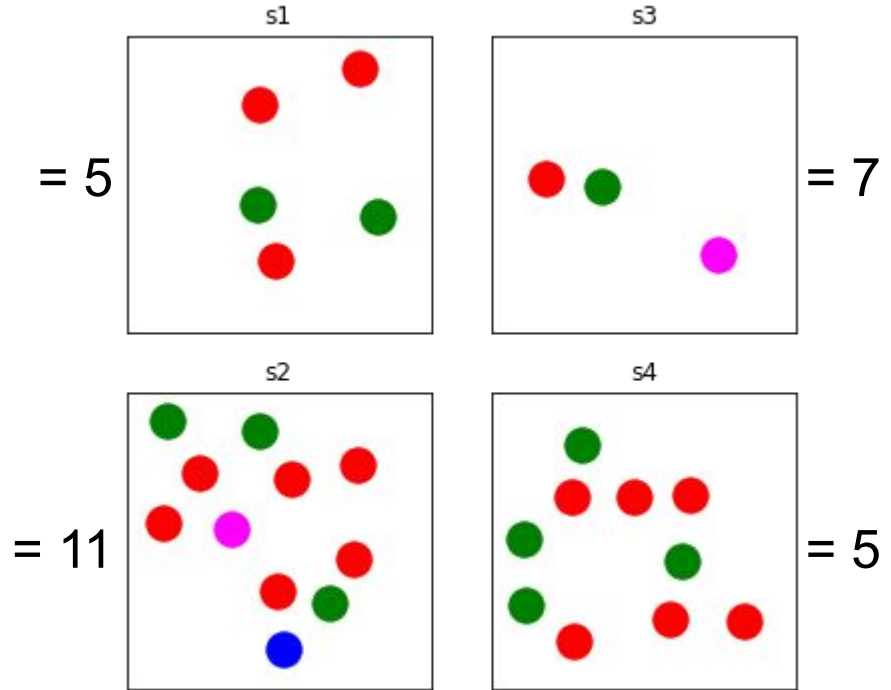
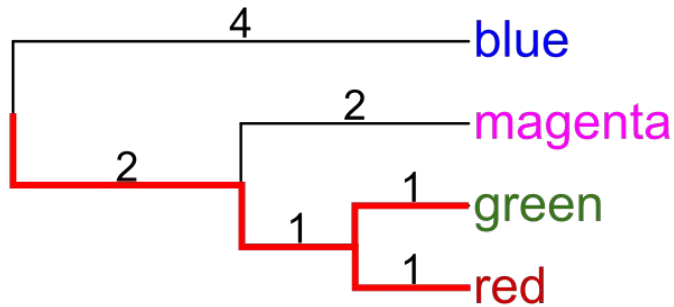

Daniel Faith



Alpha Diversity: skin microbiome

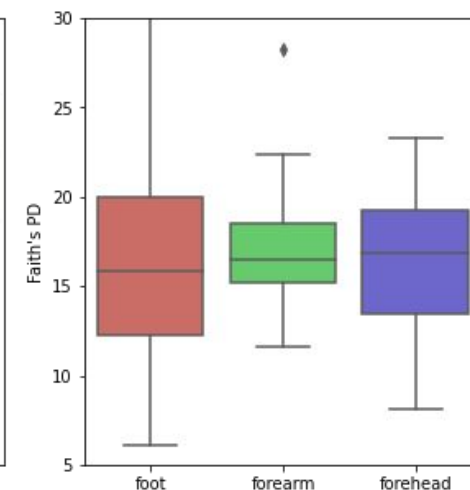
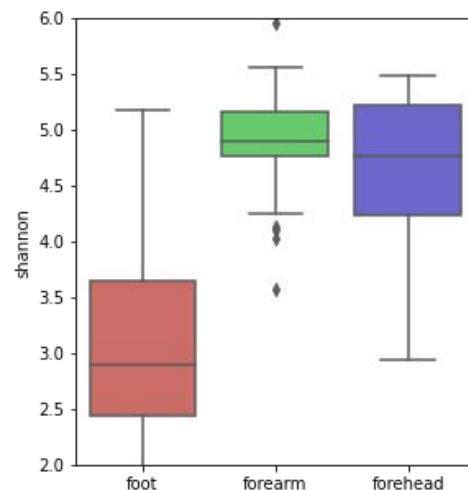
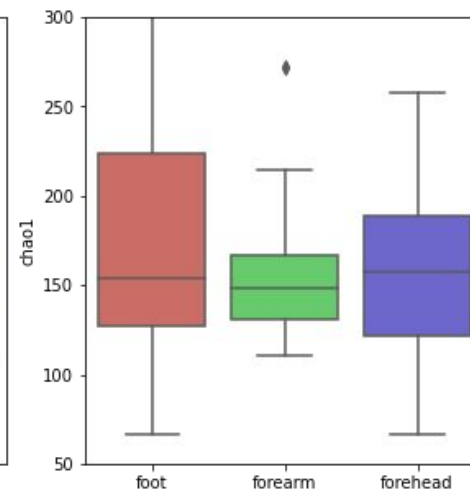
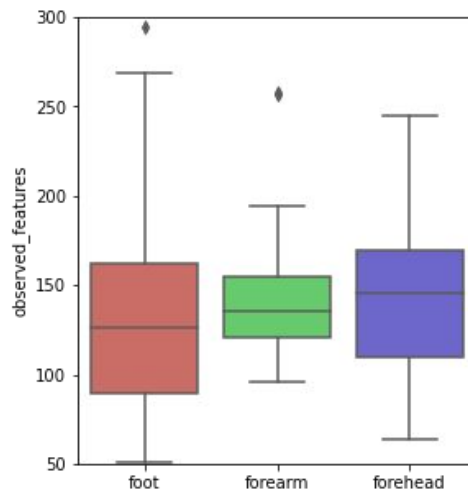
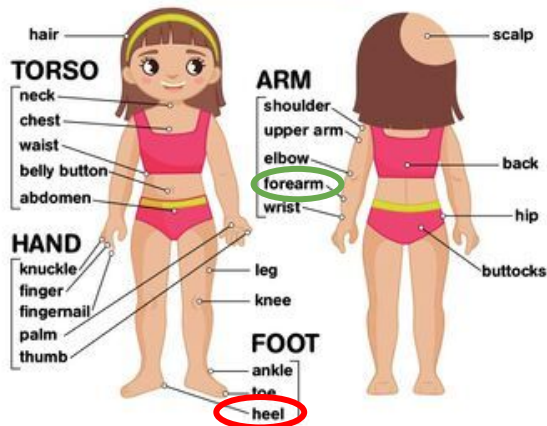

<https://reference.yourdictionary.com/resources/parts-of-the-body-for-kids-names-and-basic-functions.html>

3. Beta Diversity

- a. Jaccard
- b. Bray-Curtis
- c. UniFrac

3. Beta Diversity

- pair of samples at a time
- "how different are **two** samples?"
- alternative perspectives
 - a. Jaccard
 - b. Bray-Curtis
 - c. UniFrac
- a "Distance"

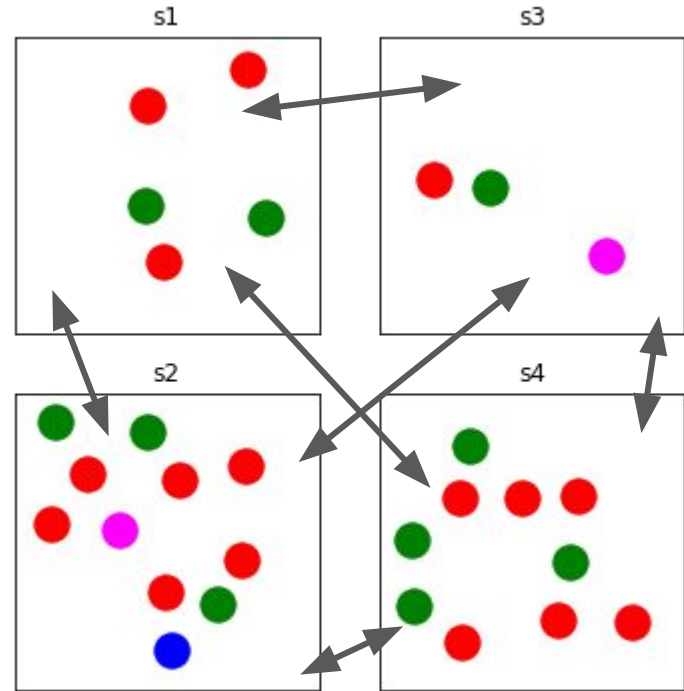

Distance Axioms

For all x_i , x_j and x_k

1. $d(x_i, x_j) \geq 0$.

2. $d(x_i, x_j) = 0$, iff x_i is equal to x_j .

3. $d(x_i, x_j) = d(x_j, x_i)$.

4. $d(x_i, x_j) \leq d(x_i, x_k) + d(x_k, x_j)$.

Distance Axioms

For all x_i , x_j and x_k

1. $d(x_i, x_j) \geq 0$. **non-negativity**
2. $d(x_i, x_j) = 0$, iff x_i is equal to x_j . **identity**
3. $d(x_i, x_j) = d(x_j, x_i)$. **symmetry**
4. $d(x_i, x_j) \leq d(x_i, x_k) + d(x_k, x_j)$. **no wormholes**

3. Beta Diversity - a: Jaccard

Fraction of unique features,
regardless of abundance.

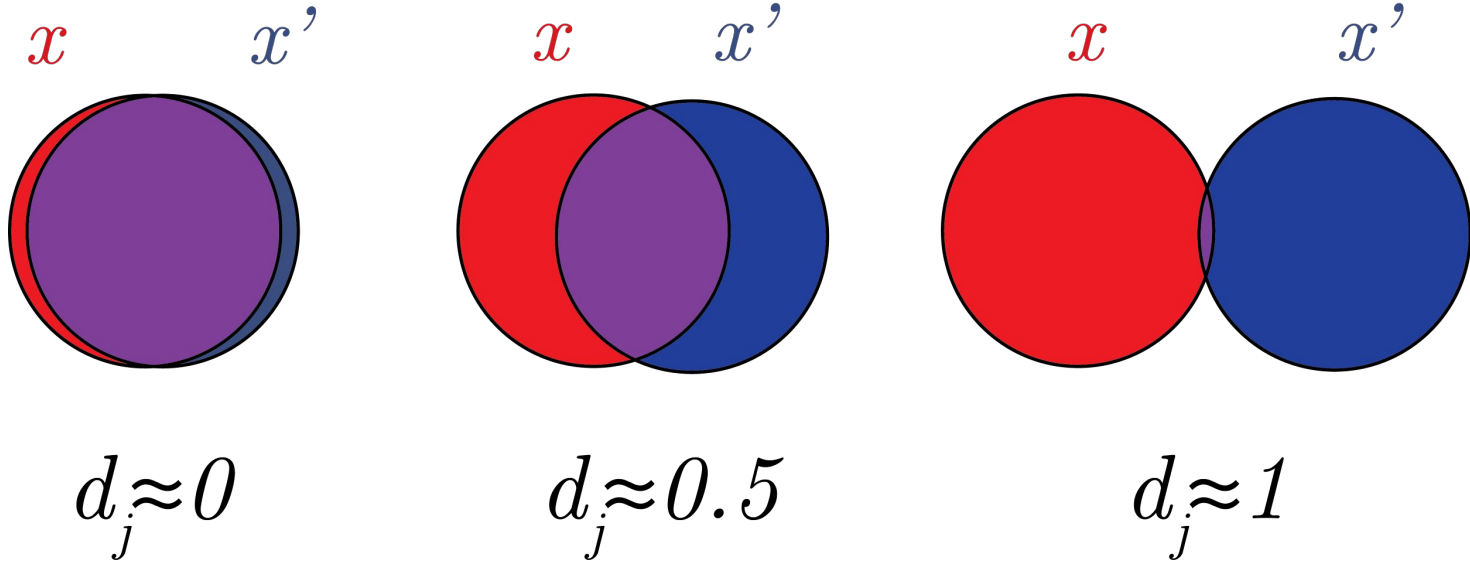

Paul Jaccard



Jaccard, Paul. *Nouvelles recherches sur la distribution florale*. 1908.

3. Beta Diversity - a: Jaccard

Fraction of unique features,
regardless of abundance.

$$J(A, B) = 1 - \frac{A \cap B}{A \cup B}$$

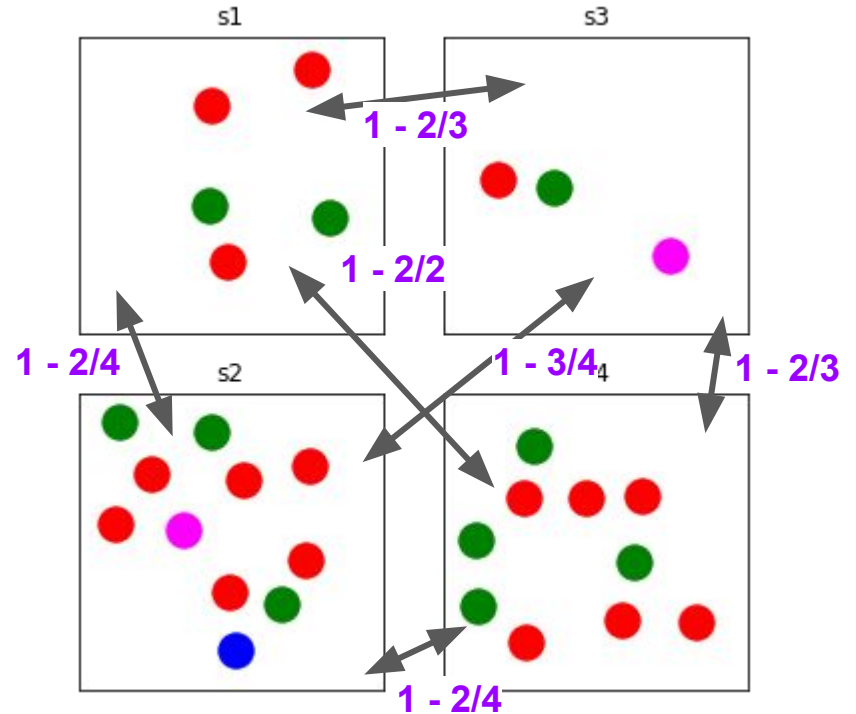

Paul Jaccard



Jaccard, Paul. *Nouvelles recherches sur la distribution florale*. 1908.

3. Beta Diversity - b: Bray & Curtis

compares relative abundances

$$\sum |u_i - v_i| / \sum |u_i + v_i|$$

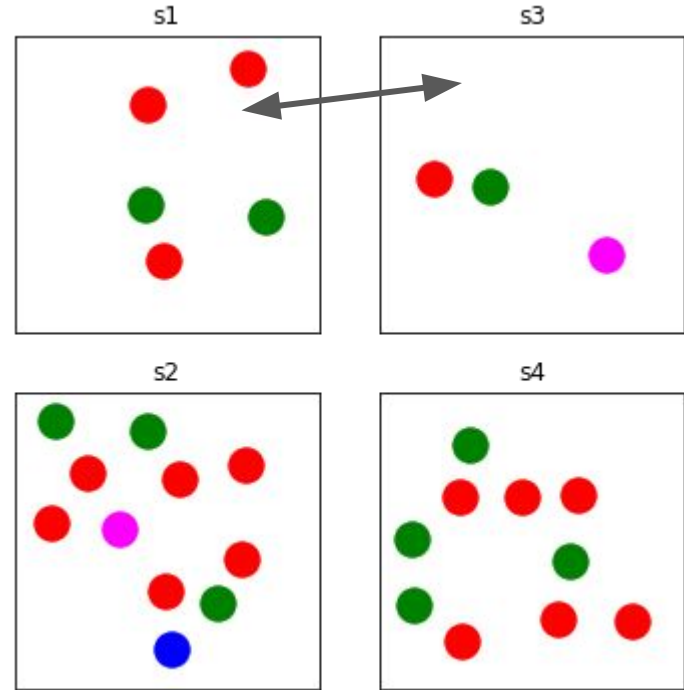

J. Roger Bray & John T. Curtis



3. Beta Diversity - b: Bray & Curtis

compares relative abundances

$$\sum |u_i - v_i| / \sum |u_i + v_i|$$

i = red, green, magenta, blue
 u = s1
 v = s2

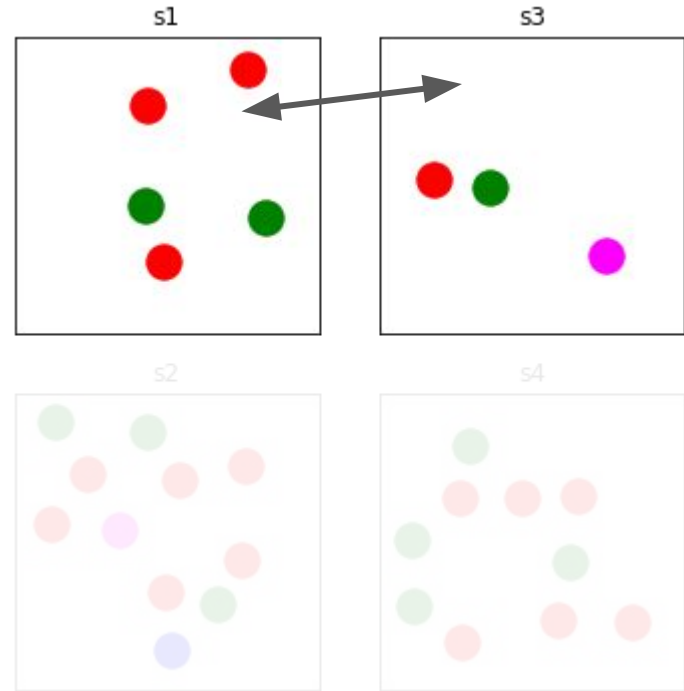

J. Roger Bray & John T. Curtis



3. Beta Diversity - b: Bray & Curtis

compares relative abundances

$$\sum |u_i - v_i| / \sum |u_i + v_i|$$

$i = \text{red, green, magenta, blue}$

$u = s1$

$v = s2$

$$\frac{|3-1| + |2-1| + |0-1| + |0-0|}{|3+1| + |2+1| + |0+1| + |0+0|}$$

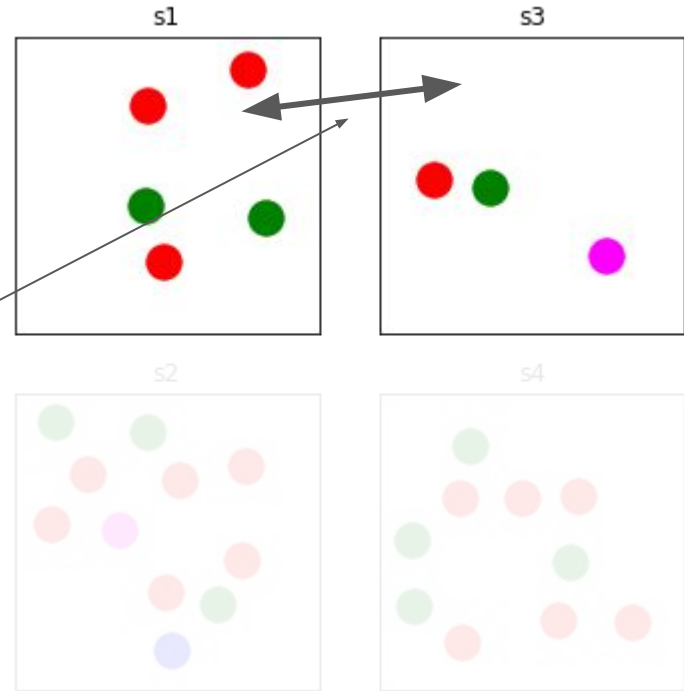

J. Roger Bray & John T. Curtis



3. Beta Diversity - b: Bray & Curtis

compares relative abundances

$$\sum |u_i - v_i| / \sum |u_i + v_i|$$

i = red, green, magenta, blue
 u = s1
 v = s2

$$\frac{|3-1| + |2-1| + |0-1| + |0-0|}{|3+1| + |2+1| + |0+1| + |0+0|} = \frac{2 + 1 + 1 + 0}{4 + 3 + 1 + 0} = \frac{4}{8}$$

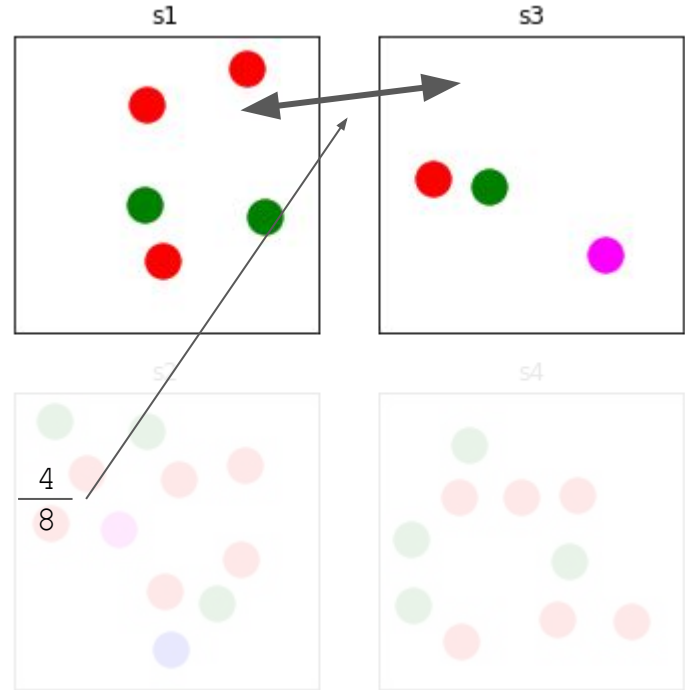

J. Roger Bray & John T. Curtis



3. Beta Diversity - b: Bray & Curtis

compares relative abundances

$$\sum |u_i - v_i| / \sum |u_i + v_i|$$

i = red, green, magenta, blue
 u = s1
 v = s4

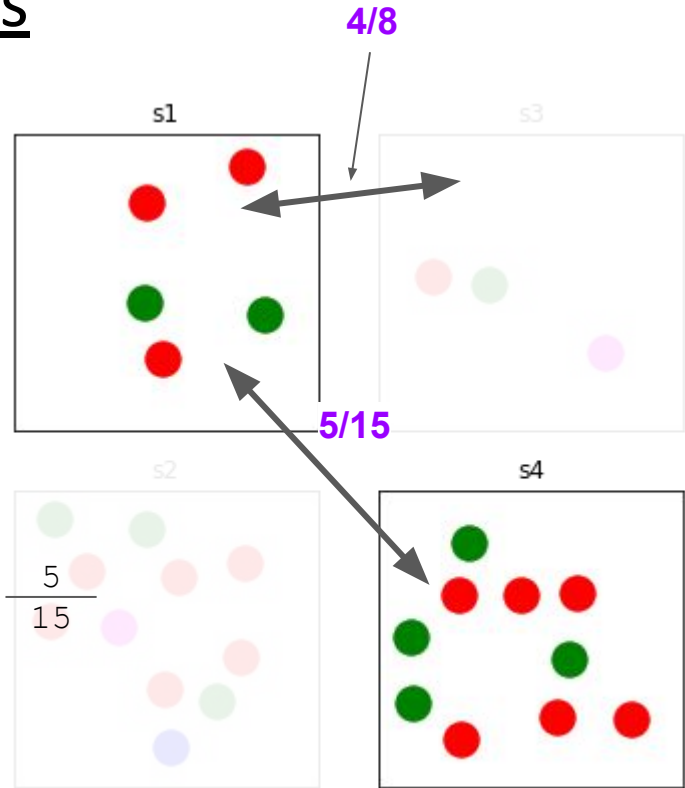

$$\frac{|3-6| + |2-4| + |0-0| + |0-0|}{|3+6| + |2+4| + |0+0| + |0+0|} = \frac{3 + 2 + 0 + 0}{9 + 6 + 0 + 0} = \frac{5}{15}$$

J. Roger Bray & John T. Curtis



3. Beta Diversity - c: UniFrac

- Measures the fraction of unique branch length
- needs a phylogenetic tree!

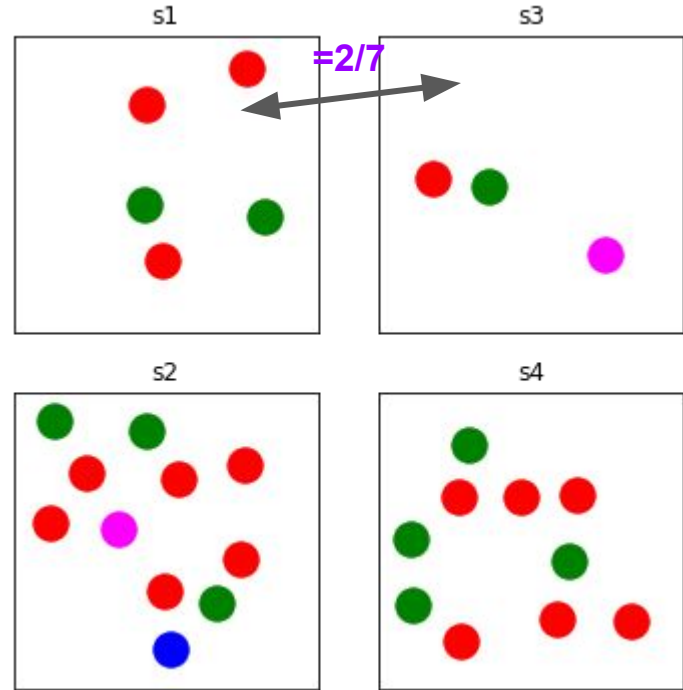
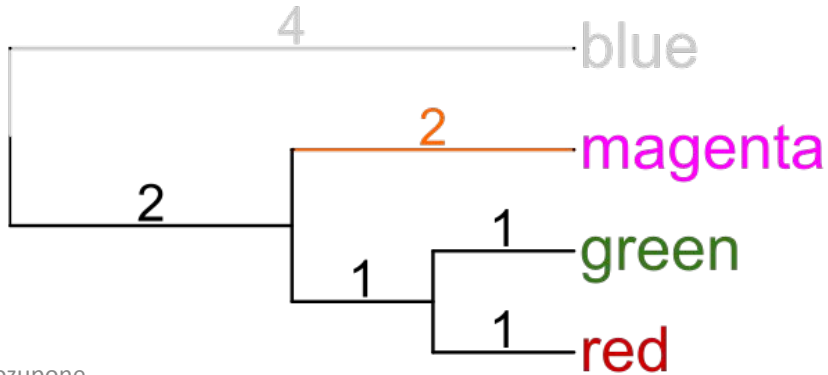

Catherine Lozupone



3. Beta Diversity - c: UniFrac

- Measures the fraction of unique branch length
- needs a phylogenetic tree!

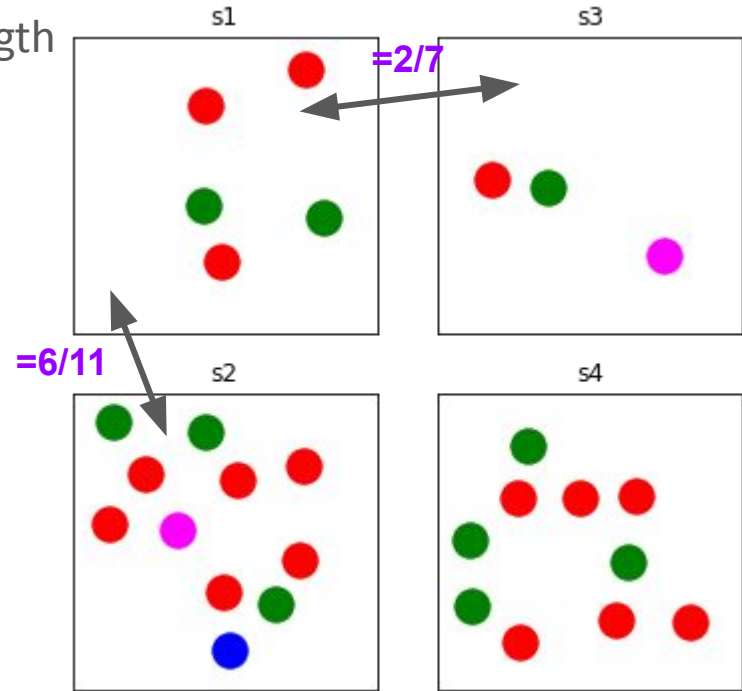
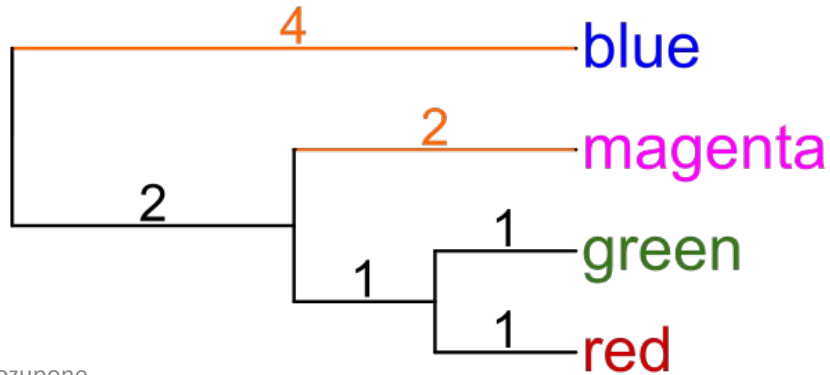

Catherine Lozupone



3. Beta Diversity - c: UniFrac

- Measures the fraction of unique branch length
- needs a phylogenetic tree!

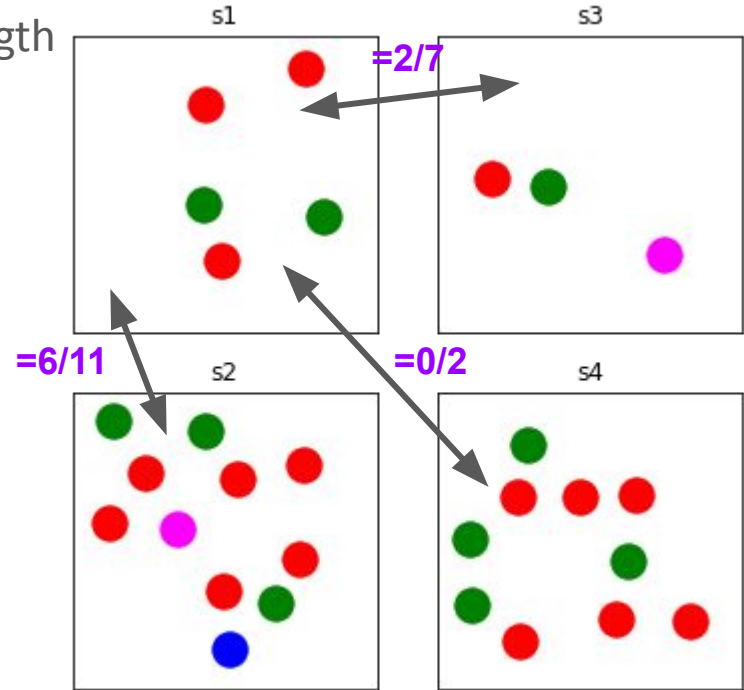
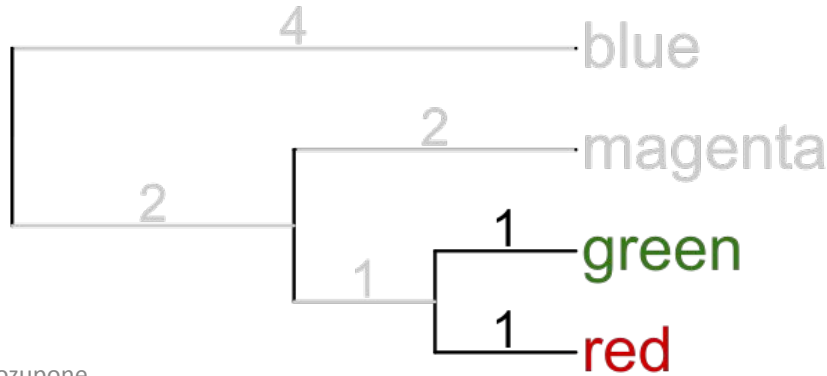

Catherine Lozupone



Which metric to use?



Selecting a metric

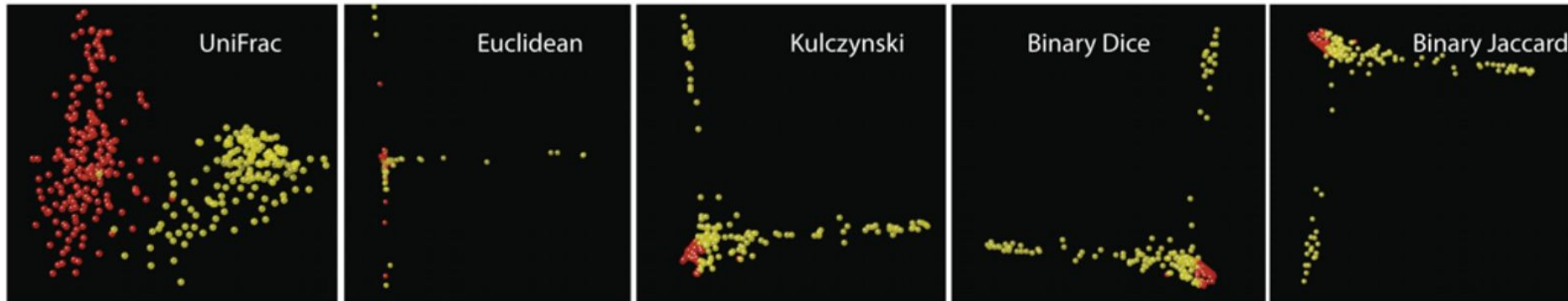

- Vertebrate Gut
- Free living

Hamady, Micah, and Rob Knight. "Microbial community profiling for human microbiome projects: Tools, techniques, and challenges." *Genome research* 19.7 (2009): 1141-1152.

Selecting a metric

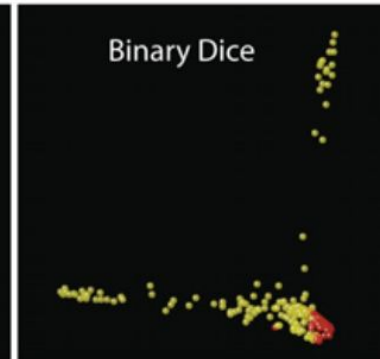
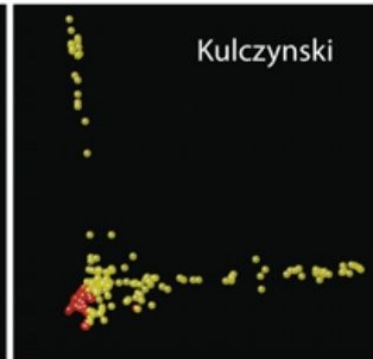
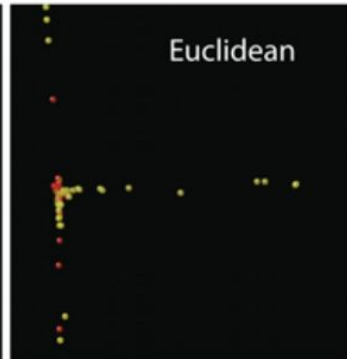
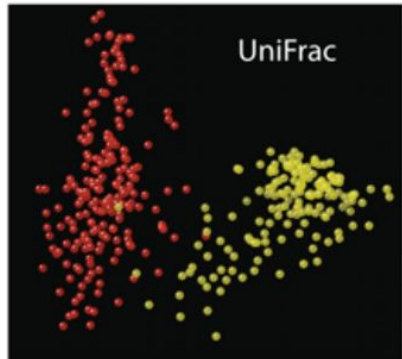
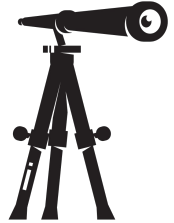
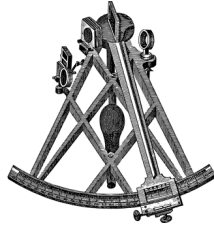

- Vertebrate Gut
- Free living

4. Dimensionality Reduction (PCoA)

Screenshot of Microsoft Excel showing a data table with 10 features and 6 samples.

	Sample A	Sample B	Sample C	Sample D	Sample E	Sample F
Feature 1	553	236	10	179	465	587
Feature 2	442	282	14	496	243	834
Feature 3	714	130	13	744	231	436
Feature 4	46	19	6	25	203	239
Feature 5	876	421	0	376	497	87
Feature 6	955	131	12	290	984	705
Feature 7	639	232	24	646	398	858
Feature 8	280	276	8	559	511	860
Feature 9	607	360	3	107	410	341
Feature 10	970	141	20	56	823	342

Screenshot of LibreOffice Calc showing a distance matrix for the data above. The window title is "distance-matrix.tsv - LibreOffice Calc".

	A	B	C	D	E
1		s1	s2	s3	s4
2	s1	0.00	0.50	0.33	0.00
3	s2	0.50	0.00	0.25	0.50
4	s3	0.33	0.25	0.00	0.33
5	s4	0.00	0.50	0.33	0.00
6					
7					

Footer: Sheet 1 of 1 | Default | English (USA) | Average: ; Sum: 0

<https://bit.ly/2LHMDFC>

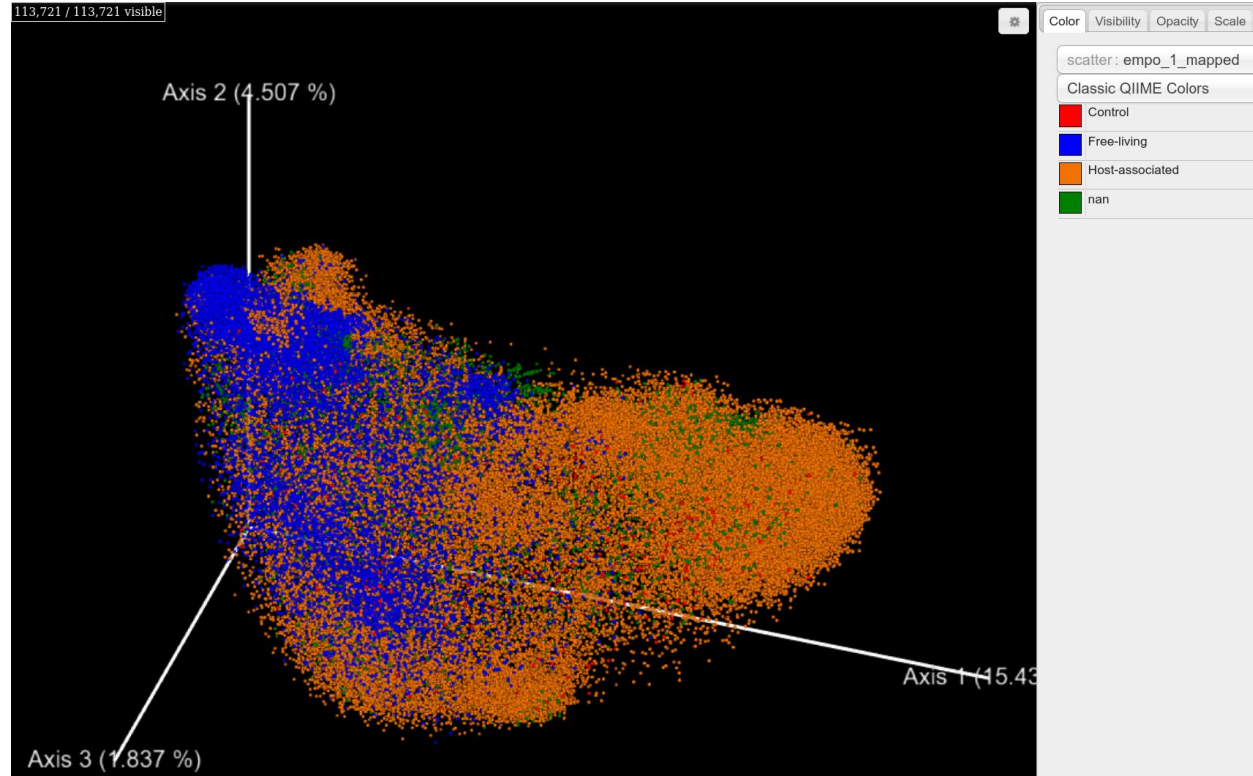

Four World Map Projections

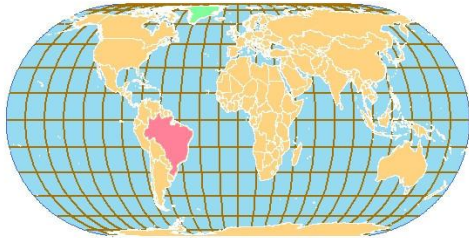

Eckert IV

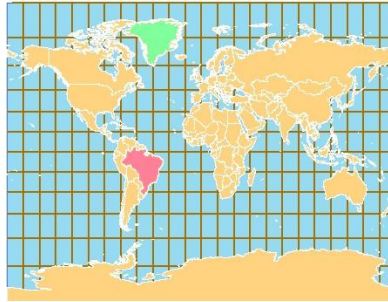

Gall Stereographic

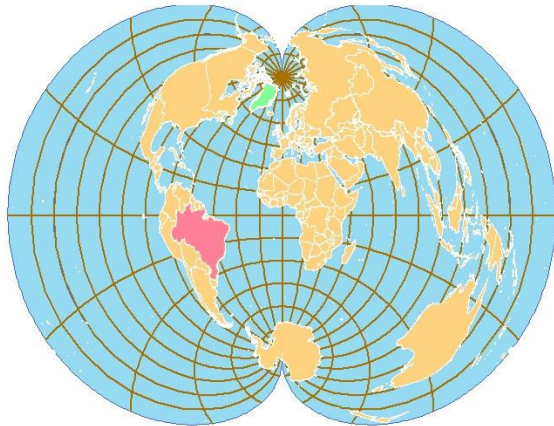

Polyconic

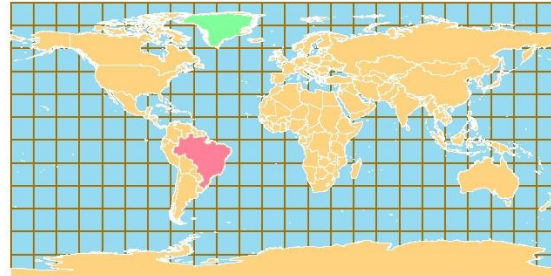

Plate Carree

area in km²

Brazil: 8,515,767

Greenland: 2,166,086

https://en.wikipedia.org/wiki/List_of_countries_and_dependencies_by_area

Principal Scale 1:375,000,000
Created by Matt Sandee 02/10
Data Source: ESRI 2008

	Tuesday, Oct 8th	Wednesday, Oct 9th	Thursday, Oct 10th
10:00-10:30		QIIME2 and Qiita	Buffer for Hands-On, Coffee break in-between
10:30-11:00		Qiita Hands-On	
11:00-11:30	Welcome & Intro		
11:30-12:00	From raw data to feature tables	Coffee Break (~15min)	Coffee Break (~15min)
12:00-12:30		Qiita Hands-On	Buffer for Hands-On
12:30-13:00		Lunch Break	Closing remarks and Farewell
13:00-13:30	Lunch Break		
13:30-14:00		QIIME2 Hands-On	
14:00-14:30	Sequence quality control		
14:30-15:00	Coffee Break	Coffee Break	
15:00-15:30	QC Hands-on	Diversity Calculation	
15:30-16:00		QIIME2 Hands-On (cont'd.)	
16:00-16:30			